

# User Manual of MPPT Solar Charging Controller

# AMSAN

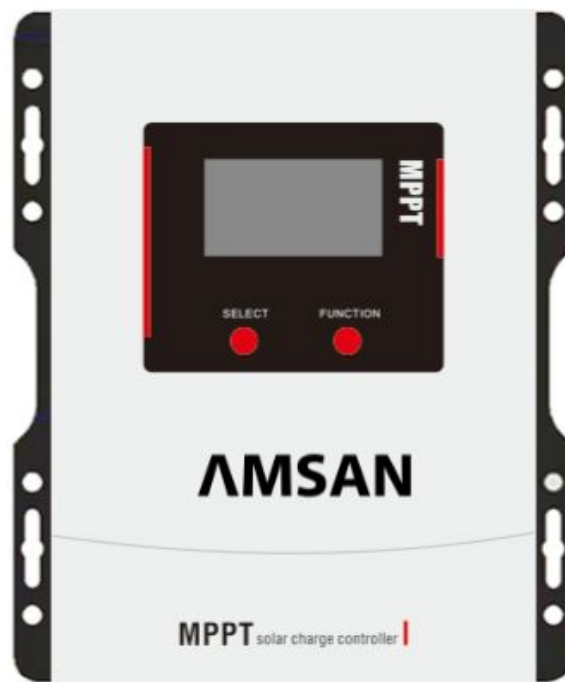



Important safety instructions (This manual contains important information about the safe installation and operation of the solar charge controller. Please keep this manual for future reference.)

This manual contains all the safety, installation and operation instructions of the series solar charge controller (hereinafter referred to as “controller”):

- ◇ This manual contains important information about the safe installation and operation of the solar charge controller. Please keep this manual for future reference.
- ◇ Mount the controller indoors only. Prevent exposure to the elements and do not allow any contact with water.
- ◇ Please install the controller in a well ventilated place to ensure adequate heat dissipation from the controller's heat sink.
- ◇ It is recommended that safety and circuit breakers be connected to the input, load and battery terminals to prevent the danger of electric shock in use.
- ◇ Power connections must remain tight to avoid potential dangers and excessive heating from a loose connection.
- ◇ If the display is not displayed normal at the first time, please cut off the fuse or circuit breaker immediately and check the line if it is connected correctly.
- ◇ When the controller is in the normal charging mode, please DO NOT disconnect the battery otherwise the DC load would be damaged.

# Contents

1 . MPPT Controller General Information. . . . .	1
1 . 1 Overview. . . . .	1
1 . 2 Characteristics. . . . .	2
1 . 3 Maximum Power Point Tracking Technology. . . . .	3
1 . 4 Battery Charging Stage. . . . .	4
1 . 5 Accessories(optional). . . . .	5
2 . Installation Instructions. . . . .	5
2 . 1 Selecting the Mounting Location. . . . .	5
2 . 2 Safe Distance. . . . .	5
2 . 3 Precautions for Controller Installation. . . . .	6
3 . Controller Connection. . . . .	6
3 . 1 Connection of the PV Power System. . . . .	6
3 . 2 Serial connection (string) of PV modules. . . . .	6
3 . 3 PV Array Input Total Power. . . . .	7
3 . 4 Model of wires and breaker. . . . .	7
3 . 5 Controller opening and closing steps. . . . .	8
4 . Operation. . . . .	9
4 . 1 Buttons. . . . .	9
4 . 2 LCD Display. . . . .	10
4 . 3 Setting. . . . .	12
4 . 4 Operation and use of lithium battery mode. . . . .	17
5 . Protection function, trouble shooting and system maintenance. . . . .	18
5 . 1 Protection function. . . . .	18
5 . 2 Troubleshooting. . . . .	19
5 . 3 System maintenance. . . . .	19
6 . Parameters. . . . .	20

# 1. MPPT Controller General Information

## 1.1 Overview

Controller based on multiphase synchronous rectification technology(MSRT)and advanced MPPT control algorithm, has the features of high response speed ,high reliability, and high industrial standard. MSRT can guarantee very high conversion efficiency in any charge power, which sharply improves the energy efficiency of solar system; Advanced MPPT control algorithm minimize the maximum power point loss rate and loss time, to ensure the tracking efficiency, corresponding speed as well as high conversion efficiency under high or low power, so that in any situation, products can rapidly track the maximum power point(MPP) of PV array to obtain the maximum energy of the panel. The limitation function of the charging power and current, and automatic power reduction function fully ensure the stability when works with oversize PV modules and operate under high temperature environment.

With the adaptive three-stage charging mode based on digital control circuit, controllers can effectively prolong the life-cycle of battery and significantly improve the system performance. All-around electronic protections, including overcharging, over discharging, and PV reverse polarity protection, effectively ensure the safer and more reliable operation of the solar system for a longer service time.

### Features:

- ◆ Advanced MPPT technology & ultra-fast tracking speed, with tracking efficiency no less than 99.5%.
- ◆ Maximum DC/DC transfer efficiency is as high as 98.5%, full load efficiency is up to 97%.
- ◆ Advanced MPPT control algorithm will minimize the MPP loss rate and loss time.
- ◆ The accuracy of the recognition and tracking at the highest point of multiple-peaks MPP.
- ◆ The wider range of MPP operating voltage.
- ◆ Auto control system to limit the charging power & current go over the rated value.
- ◆ Support the lead-acid and lithium batteries.
- ◆ It has a settable battery temperature compensation function.
- ◆ Real-time energy recording and statistical function.
- ◆ Automatic over-temperature power reduction function.
- ◆ It has the protection function of photovoltaic panel input reverse connection and battery reverse connection.

## 1.2 Characteristics

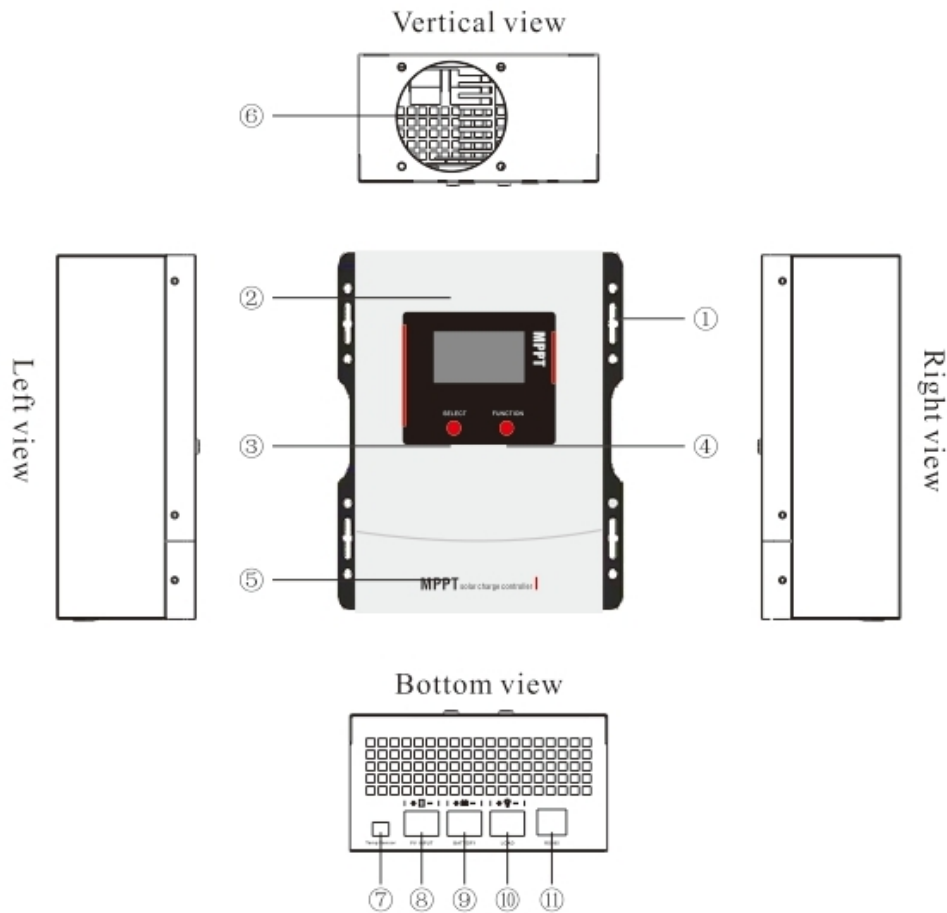

Item	Name	Item	Name
1	Mounting holes	7	Temperature sensor(1)
2	Cabinet	8	PV terminals
3	Selection button	9	Battery terminals
4	Function button	10	Load terminals
5	Terminal cover	11	Rs485 port(2)
6	Fan vent	12	/

- (1) Connect the remote temperature sensor and detect the temperature of the battery.  
The sampling distance needs to be less than or equal to 20 meters.

**!** **Note:** When the controller is not connected to the remote temperature sensor or the temperature sensor is damaged, the system will charge or discharge the battery by default at 25°C without temperature compensation.

- (2) When the communication interface is connected to a peripheral

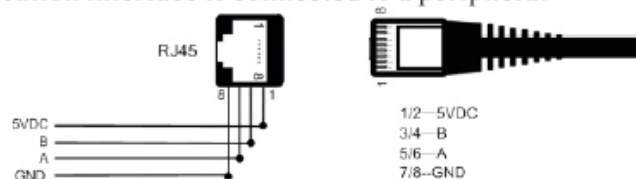



### 1.3 Maximum Power Point Tracking Technology

Due to the nonlinear output of a solar panel or solar array, there is a maximum energy point (Max Power Point, or MPP) on the output curve at which the solar panel achieves its highest efficiency. Traditional solar charge controllers with switch charging PWM technology cannot track this highest efficiency point of a solar panel, so most of the time they work with reduced efficiency and do not extract the full energy available from the solar panel.

The below figure is the maximum power point curve of a solar panel. The shaded area is the charging range of a standard PWM controller. The MPPT technology of this controller can shift the point on the curve to the higher current, and raise the efficiency by 20%-60% compared to a standard PWM controller. (The efficiency may be different due to the working environment.)

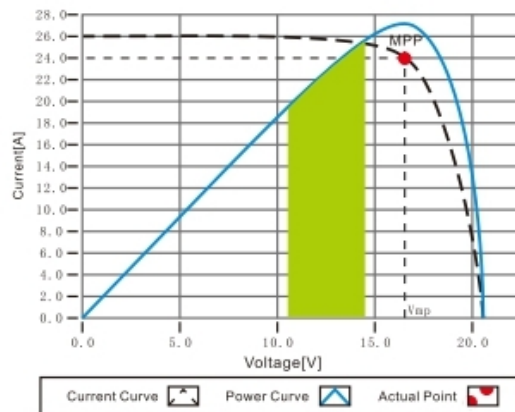

Maximum Power Point Curve

In practice, due to shading from clouds, trees, snow etc, a solar panel might have multiple MPP points, but in reality there is only one true Maximum Power Point (see below examples):

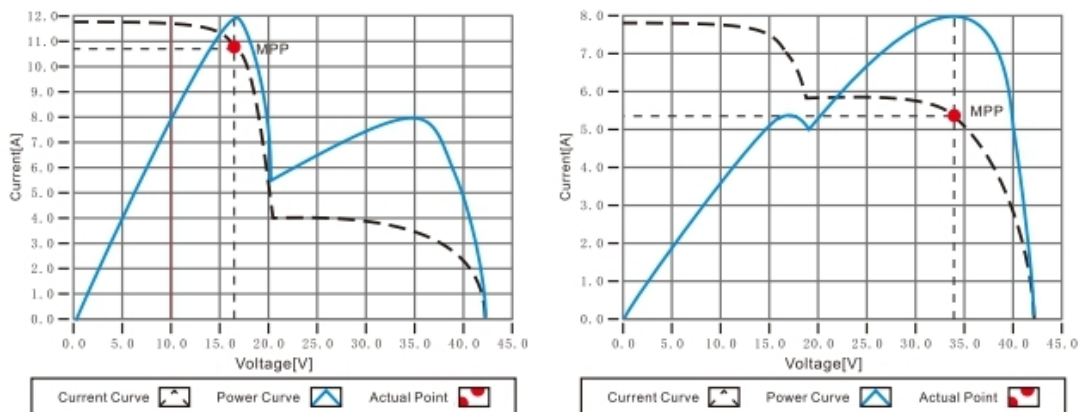

Curves with multiple MPP points

If there are multiple MPPT points, if there is no good algorithm, it will lead to work on the unreal MPPT point. This solar charge controller has a special MPPT technology that can handle multiple MPPT points and track the true MPPT point quickly and accurately, improving the system efficiency and avoiding energy waste.

## 1.4 Battery Charging Stage

The controller has 3 stages charge mode, Constant Current Charging (Bulk Charging), Constant Voltage Charging (CV) and Floating Charging (CF) for rapid, efficient, and safe battery charging.

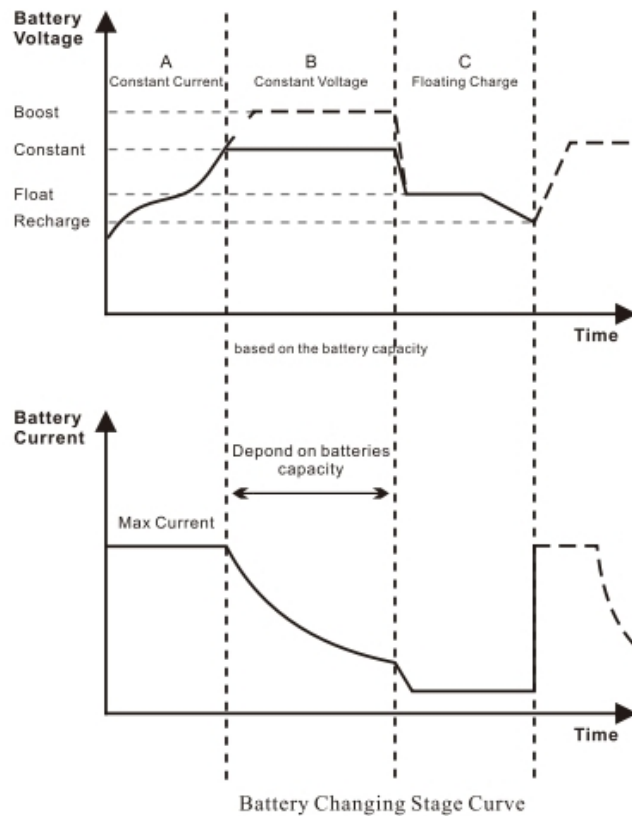

### a) Battery Changing Stage Curve

In this stage, the battery voltage has not yet reached the constant voltage point (Equalize or Boost Voltage) and the controller operates in a constant current mode, delivering its maximum current to the batteries (MPPT charging).

### b) Constant Voltage Charging: CV (Constant and Boost Charging)



When the battery voltage reaches the constant voltage set point, the controller will start to operate in constant voltage charging mode, this process the charging current will drop gradually.

### c) Floating Charging: CF

After the constant voltage stage, the controller will reduce charging current to maintaining the battery voltage on the Floating Voltage set point. Charging the battery with a smaller current and voltage on Floating Voltage stage, while maintaining full battery storage capacity.

In Floating charging stage, loads are able to obtain almost all power from solar panel. If loads exceed the power, the controller will no longer be able to maintain battery voltage in Floating charging stage. If the battery voltage remains below the Recharge Voltage, the system will leave Floating charging stage and return to Bulk charging stage.

## 1.5 Accessories(optional)

1	Remote Temperature Sensor(RTS300R47K)		Acquisition of battery temperature for undertaking temperature compensation of control parameters, the standard length of the cable is 3m (length can be customized). The RTS300R47K connects to the port ① on the controller. NOTE: The temperature sensor short-circuited or damaged, the controller will be charged or discharged at the default temperature 25°C.
2	USB to RS485 cable		USB to RS485 converter is used to monitor each controller using Solar Station PC software. The length of cable is 1.5m.

## 2. Installation Instructions

### 2.1 Selecting the Mounting Location

The position should be taken into consideration of the weight and size of the controller.

The ambient temperature of the position should be within the range of -20°C ~50°C.

A good ventilation environment should be maintained in the position.

Install position should avoid direct sunlight



Do not place this product outdoors, If the machine is not used in a standard way, it will be damaged by water immersion Will not be covered by the warranty period.

### 2.2 Safe Distance

Refer to the following safety clearance to ensure that other equipment or objects are not within this range to ensure that there is sufficient space for heat dissipation.

Direction	Safe Distance
Left-Right direction	>20cm
Up-Down direction	>30cm





### 2.3 Precautions for controller installation

- ◆ Be very careful when installing the battery. For the installation of the open lead-acid battery, you should wear protective glasses. Once the battery acid is contacted, please rinse with clean water in time.
- ◆ Avoid placing metal objects near the battery to prevent the battery from short-circuiting.
- ◆ Acid gas may be generated when the battery is charged. Ensure that the environment is well ventilated.
- ◆ Virtual connection points and corroded wires may cause great heat to melt the wire insulation, burn surrounding materials, and even cause fire. Therefore, make sure that the connectors are tightened and the wires are best fixed with ties to avoid moving applications. When the wire shakes, the connector loosens.
- ◆ Only lead-acid batteries and lithium batteries within the control range of this controller can be charged.
- ◆ The system connection line is selected according to the current density not greater than 5A/mm<sup>2</sup>.

## 3. MPPT Controller Connection

### 3.1 Connection of the PV Power System

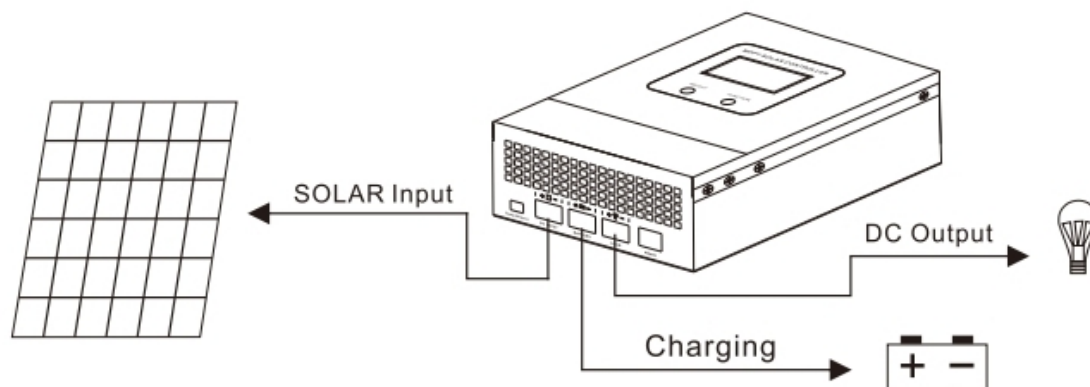

### 3.2 Serial connection (string) of PV modules

(1) The number of photovoltaic modules connected in series

As the core component of PV system, controller could be suitable for various types of PV modules and maximize converting solar energy into electrical energy. According to the open circuit voltage ( $V_{oc}$ ) and the maximum power point voltage ( $V_{mp}$ ) of the MPPT controller, the series number of different types PV modules can be calculated.

The following table is provided for general guidance only:

**20A|30A:**

System Voltage	36cell $V_{oc}<23V$		48cell $V_{oc}<31V$		54cell $V_{oc}<34V$		60cell $V_{oc}<38V$	
	Max	Best	Max	Best	Max	Best	Max	Best
12V	4	2	2	1	2	1	2	1
24V	6	3	4	2	4	2	3	2
48V	6	5	4	3	4	3	3	3

System Voltage	72cell Voc<46V		96cell Voc<62V		Thin-Film Module Voc>80V
	Max	Best	Max	Best	
12V	2	1	1	1	1
24V	3	2	2	1	1
48V	3	2	2	2	1

**NOTE:** The above parameter values are given under Standard Test Conditions (STC): irradiance 1000W/m<sup>2</sup>, Module Temperature 25°C, Air Mass 1.5.)

### 3.3 PV Array Input Total Power

This MPPT controller has a limiting function of charging current, the charging current will be limited within rated range. Therefore, the controller will charge the battery with the rated charging power even if the input power at the PV exceeds. Such as: for 12V Solar System with 30A controller, no matter the input power of the solar panel is greater than the rated number, the charging current will not be more than 30A. The actual operation power of the PV array conforms to the conditions below:

1) PV power less or equal to controller rated power, the maximum power of the controller is equal to the actual power of the PV array.

2) If the PV array actual power is more than the controller nominal rated power, the controller will reduce the PV array power and charge the battery at its nominal rated power.

According to the "sunshine time curve", if the power of the photovoltaic array exceeds the rated charging power of the controller, the charging time with the rated power will be extended, so more energy can be obtained to charge the battery. However, in practical applications, the maximum power of the photovoltaic array must not exceed 2 times the controller's customer-specified charging power; if it is checked that the photovoltaic array power exceeds the controller's rated charging power too much, not only the photovoltaic modules will be wasted, but also due to the influence of ambient temperature. The open circuit voltage of the array increases, which increases the probability of damage to the controller. Therefore, a reasonable configuration of the system is particularly important. For the maximum power of the PV array recommended by this controller, please refer to the following table:

Model	Rated charging current	Rated charging power	Maximum PV array power	Maximum PV open circuit voltage
20415F	20A	260W/12V	520W/12V	150V(lowest temperature) 138V (25°C)
		520W/24V	1040W/24V	
		780W/36V	1560W/36V	
		1040W/48V	2080W/48V	
30415F	30A	390W/12V	780W/12V	150V(lowest temperature) 138V (25°C)
		780W/24V	1560W/24V	
		1170W/36V	2340W/36V	
		1560W/48V	3120W/48V	

### 3.4 Model of wires and breaker

☛ The installation of inverter must strictly follow the local electrical requirements.

The output current of solar panles will be effected by the model of solar panel cell, connection setting and the light intensity,so the minimum wire size is design according to the short circuit current of solar panels.Please check the short circuit current on the manual book of solar panel. (The short circuit current will not change when the solar panels serial connect.The total short circuit current are the sum of each solar panel group when parallel connect.)The short circuit current of solar panel can not over the maximum input current of the solar charge controller.

For the convenient of turning on and off,also for the safety, we suggest you to install a breaker. Kindly choose right breaker and wires according to below chart.

Model	PV maximum input Current	PV end max Wire diameter	Rated charging current	Battery wire diameter	Circuit breaker specifications
20415F	20A	11AWG/4mm <sup>2</sup>	20A	11AWG/4mm <sup>2</sup>	40A
30415F	30A	9AWG/6mm <sup>2</sup>	30A	9AWG/6mm <sup>2</sup>	50A

### 3.5 Controller opening and closing steps

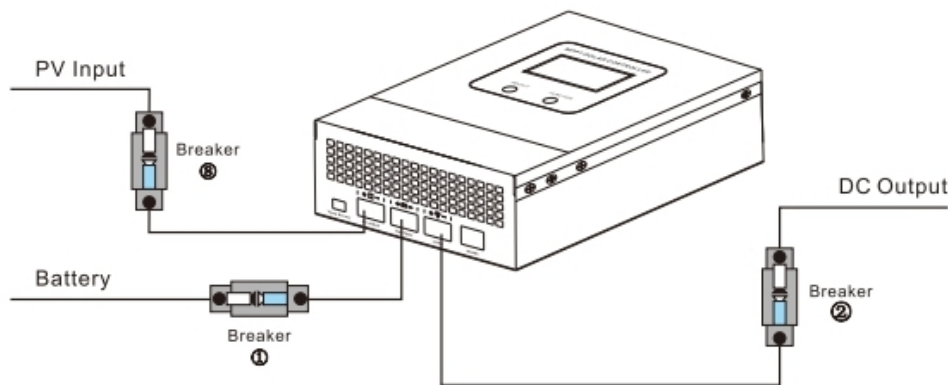

Make sure that the controller is installed and connected correctly!

**Opening process:** Step 1: open the circuit breaker ① on the battery side, make sure that the controller is connected with the battery (the LCD of the controller will display the content), and set the battery type.

Step 2: if you need to use the DC load output, then set the output control mode first, and then open the DC output circuit breaker ②.

Step 3: open the circuit breaker ③ on the input side of the solar panel PV, if the PV input voltage is in the charge range of the controller, then the controller will enter the charging state.

**Closing process:** turn off the circuit breaker in turn: ③②①



#### Caution:

1. If the system needs to connect to the inverter, please connect the inverter to the battery directly, but DO NOT connect to the load terminal of the controller.
2. When the controller is in the normal charge state, do not disconnect the battery connection, otherwise the Controller may be damaged. Therefore, the damage to the controller will not be within the warranty.

#### (2) Connect accessories

• Connect the remote temperature sensor cable (Model: RTS300R47K) Connect the remote temperature sensor cable to the interface ⑦ and place the other end close to the battery.

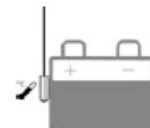

CAUTION: If the remote temperature sensor is not connected to the controller, the default setting for battery charging or discharging temperature is 25 °C without temperature compensation.

- Connect the accessories for RS485 communication, refer to the accessories list.



## 4. Controller Operation

LCD display:

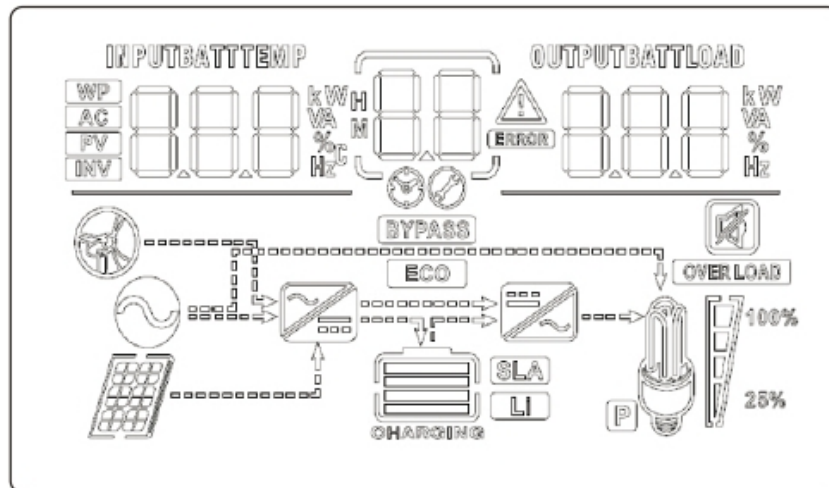

As follow is MPPT controller's LCD digital tube display number corresponding meaning:

On	-----Mean "ON"	FLD	-----Mean "FLD"
OFF	-----Mean "OFF"	GEL	-----Mean "GEL"
USER	-----Mean "USER"	SEL	-----Mean "SEL"
LIF	-----Mean "LiFeP04"	tEr	-----Mean "LiCoMnNi02"

as follow is the digital tube display character and the English comparison table for reference

A	b	C	d	E	F	G	H	I	J	K	L
M	n	o	P	q	r	S	t	U	v	W	X
Y	Z	1	2	3	4	5	6	7	8	9	0

### 4.1 Buttons

Key position	Instructions
SELECT	tap the SELECT button to browse or perform a selection function in the setting mode.
FUNCTION	Under the setting model, press "FUNCTION", occur word flicker, means start setting parameter.After finish setting,press"FUNCTION" to confirm your setting.
Setting mode	Long press "FUNCTION",when occur  ,means come to setting model. Under the setting model, press "FUNCTION" lightly,happen word flicker, press the "SELECT" to set the parameters.When finish setting,press "FUNCTION" to confirm the setting.Auto exit setting model when no any operation within 3 mins.

## 4.2 LCD display

### (1) Browsing interfaces

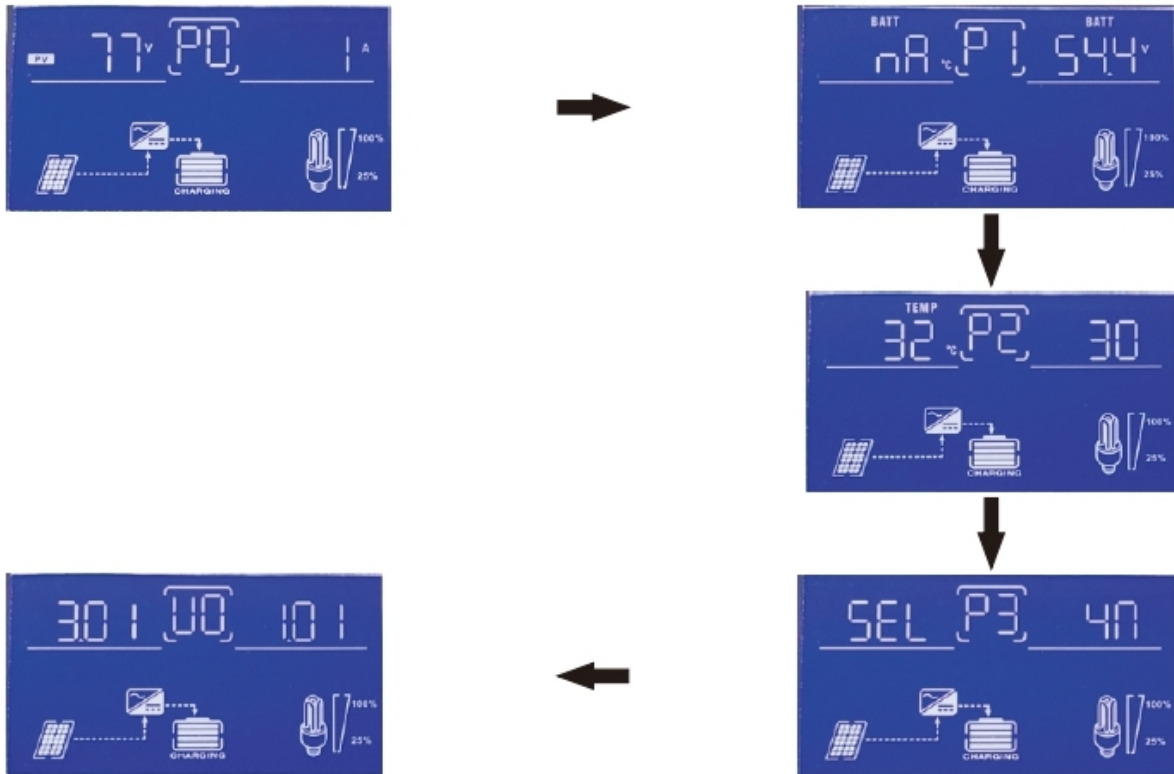



LCD Display content	Descriptions		
	The upper left side displays the voltage connected to the photovoltaic panel	P0	The charging current value is displayed on the upper right side

LCD Display content	Descriptions		
	The upper left side displays the battery temperature (external temperature sensor needs to be connected)	P1	Battery voltage is displayed on the upper right side

LCD Display content	Descriptions		
	The upper left side displays the operating temperature of the current machine	P2	The upper right side shows the rated specifications of the machine



LCD Display content	Descriptions		
	The currently selected battery type is displayed on the upper left side	P3	The upper right side displays the operating voltage of the currently running machine system









LCD Display content	Descriptions		
	The upper left side displays the system version number of the current machine kernel	U0	The upper right side displays the version number of the current LCD display kernel

(2) Setting interfaces



(Remark: please refer to the set mode description of the key operation in the 4.1 chapter)

### (3) Fault alarm display

Fault indicator icon	Code	Descriptions
	021	Communication connection failed
	032	MCU Over temperature warning
	033	PV input over voltage warning
	034	Battery over heat warning
	035	Over heating inside the controller warning
	036	Battery low voltage warning
	038	DC Loads overloaded warning
	044	Battery Voltage abnormal warning
ERROR	051	MCU Over temperature fault
ERROR	052	Temperature sensor fault
ERROR	053	Over heating inside the controller fault
ERROR	054	Battery over heat fault
ERROR	055	DC Loads output fault
ERROR	056	Battery overcharged fault
ERROR	059	Mismatched number of battery sections fault

## 4.3 Operation settings

### (1) Battery type

① The type of batteries supported by the MPPT charge controller

Battery	Sealed Battery(by default)	Lithium battery	Lithium iron phosphate
	GEL battery		Ternary lithium
	Flooded battery		Customizing
	Customizing		

② Control voltage parameters of battery

◆ Battery parameters

Voltage parameters are 25°C/12V system parameters, 24V system parameters X2, 36V system parameters X3, 48V system parameters X4, 96V system parameters X8

Voltage control parameters	VRLA Battery	GEL battery	Flooded battery	Customizing
Overvoltage disconnect voltage	15.9V	15.7V	16.1V	9~17V
Charging limited voltage	15.4V	15.2V	15.6V	9~17V
Overvoltage disconnection recovery voltage	15.4V	15.2V	15.6V	9~17V
Strong charging voltage	14.4V	14.2V	14.6V	9~17V
Float charge voltage	13.6V	13.6V	13.6V	9~17V
Boost recovery voltage	13V	13V	13V	9~17V
Low voltage disconnect recovery voltage	11.5V	11.5V	11.5V	9~17V
Undervoltage alarm recovery voltage	11.5V	11.5V	11.5V	9~17V
Undervoltage alarm voltage	11.4V	11.4V	11.4V	9~17V
Undervoltage disconnect voltage	11V	11V	11V	9~17V
Strong charge duration time	120 min	120 min	120 min	120 min

1. When the default battery type is selected, the battery voltage control parameters cannot be changed by default; if you want to change the battery voltage control parameters, you can only select the corresponding "Customizing" type.

2. "Customizing" must follow the logic

- ▶ Strong charge voltage > Float charge voltage
- ▶ Low voltage disconnect recovery voltage > Low voltage break voltage



◆ Lithium battery parameters



The voltage parameters are all 25°C/12V system parameters, 24V system parameters x2, 48V system parameters x4, 96V system parameters x8.



Voltage control parameters	Lithium iron phosphate	Ternary lithium	Customizing
Overvoltage disconnect voltage	16.1V	14.1V	9~17V
Charging limited voltage	15.6V	13.6V	9~17V
Overvoltage disconnection recovery voltage	15.6V	13.6V	9~17V
Strong charging voltage	14.6V	12.6V	9~17V
Float charge voltage	14.6V	12.6V	9~17V
Boost recovery voltage	13V	12V	9~17V
Low voltage disconnect recovery voltage	11.5V	9.5V	9~17V
Undervoltage alarm recovery voltage	11.5V	9.5V	9~17V
Undervoltage alarm voltage	11.4V	9.4V	9~17V
Undervoltage disconnect voltage	11V	9V	9~17V





Warning: The lithium battery parameters can be set, but the setting must refer to the voltage parameters of the lithium battery protection board to set the corresponding parameters. The lithium battery protection board must be connected during the lithium battery charging process and the accuracy of the lithium battery protection board must not exceed 0.2V. Otherwise, the system will not be responsible for any abnormality!



		Long press "FUNCTION", when occur  , come to setting model. On the page indicating "00", press "FUNCTION" lightly, happen word flicker, press the "SELECT" to select the desired battery type, When finish setting, press "FUNCTION" to confirm the setting.			
(1) Battery type adjustment	LCD Display content		Descriptions		
			The upper left side displays the setup page code	00	The upper right display sets the battery type
					SEL Sealed Battery
					GEL GEL battery
					FLd Flooded battery
					USER Customiz battery
					tEt Ternary lithium
LIF Lithium iron phosphate					



		Long press "FUNCTION", when occur  , come to setting model. On the page indicating "01", press "FUNCTION" lightly, happen word flicker, press the "SELECT" to select the desired system voltage, When finish setting, press "FUNCTION" to confirm the setting.			
(2) System voltage regulation	LCD Display content		Descriptions		
			The upper left side displays the setup page code	01	The upper right side displays the system voltage setting type
					Code Instructions
					AUT Automatic identification of operating voltage mode
					12V Set and select 12V working voltage mode
					24V Set and select 24V working voltage mode
48V Set and select 48V working voltage mode					

		Long press "FUNCTION", when occur  , come to setting model. On the page indicating "02", press "FUNCTION" lightly, happen word flicker, press the "SELECT" to select the desired percentage of the charging current size, When finish setting, press "FUNCTION" to confirm the setting.		
(3) charging current regulation	LCD Display content		Descriptions	
			The upper left side displays the setup page code	02
5~100% adjustable				





(4)Load lock voltage regulation	Long press "FUNCTION",when occur  ,come to setting model.On the page indicating "03",press "FUNCTION" lightly,happen word flicker,press the "SELECT" to select the desired DC load output undervoltage protection voltage value ,When finish setting,press "FUNCTION" to confirm the setting.				
	LCD Display content		The upper left side displays the setup page code	Descriptions	
				03	Upper right regulating load locking voltage value
		9~17V adjustable			



(5)Floating charging voltage regulation	Long press "FUNCTION",when occur  ,come to setting model.On the page indicating "04",press "FUNCTION" lightly,happen word flicker,press the "SELECT" to select the desired floating charging voltage,When finish setting,press"FUNCTION" to confirm the setting.				
	LCD Display content		The upper left side displays the setup page code	Descriptions	
				04	Upper right side regulating floating charge voltage value
		9~17V adjustable			

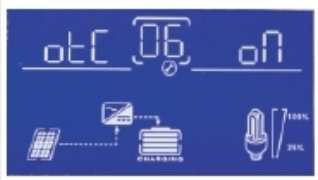

(6)Strong charging voltage regulation	Long press "FUNCTION",when occur  ,come to setting model.On the page indicating "05",press "FUNCTION" lightly,happen word flicker,press the "SELECT" to select the desired strong charging voltage,When finish setting,press"FUNCTION" to confirm the setting.				
	LCD Display content		The upper left side displays the setup page code	Descriptions	
				05	Adjust the Strong charging voltage value on the upper right side
		9~17V adjustable			





		Long press "FUNCTION",when occur  ,come to setting model.On the page indicating "06",press "FUNCTION" lightly,happen word flicker,press the "SELECT" to select ON/OFF ,When finish setting,press"FUNCTION" to confirm the setting.			
(7)DC load output switch regulation	LCD Display content		Descriptions		
			The upper left side displays the setup page code	06	Upper right adjustment on / off
					ON
OFF					

		Long press "FUNCTION",when occur  ,come to setting model.On the page indicating "07",press "FUNCTION" lightly,happen word flicker,press the "SELECT" to select the desired undervoltage recovery voltage,When finish setting,press"FUNCTION" to confirm the setting.			
(8)Undervoltage recovery voltage regulation	LCD Display content		Descriptions		
			The upper left side displays the setup page code	07	Upper right regulating undervoltage recovery voltage value
					9~17V adjustable

		Long press "FUNCTION",when occur  ,come to setting model.On the page indicating "08",press "FUNCTION" lightly,happen word flicker,press the "SELECT" to select the desired screen light setting ,When finish setting,press"FUNCTION" to confirm the setting.				
(9)LCD screen light setting	LCD Display content		Descriptions			
			The upper left side displays the setup page code	08	Upper right adjustment backlight mode	
					Lon	Always open
					Lof	Always off
Lod	Delay off					

(10)Restore factory setting	Long press "FUNCTION",when occur  ,come to setting model.On the page indicating "09",press "FUNCTION" lightly,happen word flicker,press the "SELECT" to select whether to reset the parameters,When finish setting,press"FUNCTION" to confirm the setting.				
	LCD Display content		The upper left side displays the setup page code	Descriptions	
				09	Is the upper right adjustment reset
					ON
YES					

(11)Exit setup mode page	When occur  ,come to setting model.On the page indicating "10",press "FUNCTION" lightly,happen word flicker,press the "SELECT" to select ON/OFF ,When finish setting, press "FUNCTION" to confirm the setting.				
	LCD Display content		The upper left side displays the setup page code	Descriptions	
				10	The upper right side shows whether to exit the setting page
					ON
YES					

#### 4.4 Operation and use of lithium battery mode



 Note: The lithium battery system voltage cannot be set to auto-recognition and self-adaptation. When a lithium battery needs to be inserted for use, the system voltage needs to be set to the working voltage of the currently received lithium battery.

 Operation steps:

Step1:Connect the battery input terminal to the lithium battery pack,Long press "FUNCTION" come to setting model,On the page indicating "00",press "FUNCTION" lightly,happen word flicker,press the "SELECT" to select the desired lithium battery type.  
Step2:Long press "FUNCTION" come to setting model,On the page indicating "01", press "FUNCTION" lightly,happen word flicker,press the "SELECT" to select the system voltage.(For example:if the lithium battery pack is lithium iron phosphate 16 strings, the system voltage is set to 48V)

## 5. Protection, Troubleshooting, System maintenance

### 5.1 Protections

Protections	Descriptions
PV current limiting power protection	When the photovoltaic array charging current or power exceeds the pv rated current or power, it will be charged with the rated current or power.
PV short circuit protection	When the PV is not charging, the controller will not be damaged when the PV array is short-circuited.
	 Warning: PV is forbidden to short circuit during charging, otherwise the controller will be damaged.
PV reverse connection protection	When the polarity of the photovoltaic array is reversed, the equipment will not be damaged, the display will report a fault, and it can continue to work after correction.
Anti-recharge protection at night	At night, since the battery voltage is greater than the voltage of the PV module, the battery is prevented from discharging through the PV module.
Battery reverse connection protection	When the battery polarity is reversed, the equipment will not be damaged.
Battery overvoltage protection	When the battery voltage reaches the overvoltage disconnect voltage point, it will automatically stop charging the battery to prevent damage to the battery due to overcharging.
Battery over-discharge protection	When the battery voltage reaches the undervoltage disconnection voltage point, it will automatically stop discharging the battery to prevent the battery from being damaged by over-discharge.
	 Note: This protection function will only be available when the DC load output is connected to a load discharge.
Battery overheat protection	The controller detects the battery temperature through an external temperature sensor, and stops working when the battery temperature exceeds 60°C, and resumes operation when the battery temperature falls below 55°C.
Equipment overheating protection <sup>①</sup>	The controller detects the internal temperature of the controller through an internal temperature sensor. When the temperature inside the machine exceeds 85°C, it will stop working, and resume working when it is below 70°C.
TVS high voltage surge protection	The internal circuit of this controller is designed with transient suppression diode TVS components, but it can only protect the high-voltage surge pulse with low energy. If the controller is used in areas with frequent lightning, it is recommended to install an external lightning arrester.

- ① When the internal temperature of the machine is 70°C, turn on the charging power reduction mode. For every 2°C increase, the charging power will be reduced by 5%, 10%, 20%, 30%, 40%, 50%, 70%, 90%. When the temperature reaches 85°C or higher, stop charging immediately. When the internal temperature is not more than 65°C, the maximum power tracking charge will be resumed.

E.g. 100415F 48V system

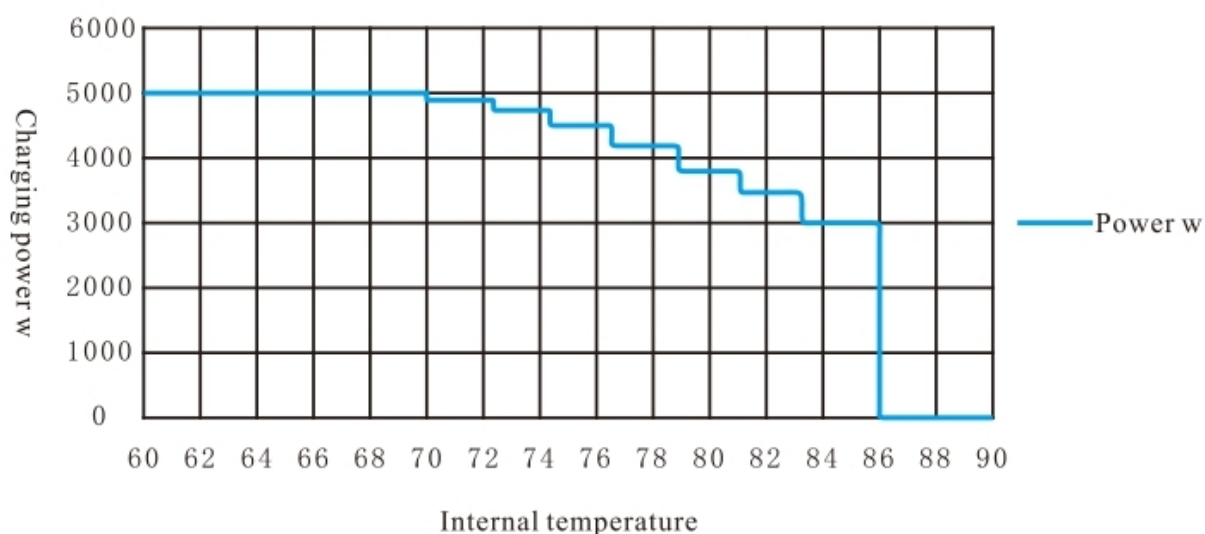



## 5.2 Troubleshooting

Descriptions	Failures	Solutions
when the sunlight is strong, charge state indication.	PV array connection is open	please check whether the wiring at both ends of the photovoltaic array is correct and whether the contact is reliable.
Normal wiring, but the controller cannot work normally.	The battery voltage is less than 11V	Measure the voltage across the battery, at least 11V to turn on the controller.
Display code is 033	PV array polarity is reversed or PV array input open circuit voltage exceeds the limit	Check whether the polarity of the two ends of the photovoltaic array input is connected correctly, and measure whether the voltage across the photovoltaic array is within the specified range.
Display code is 037	The battery is over discharge	①Automatically restore load output when the power is sufficient; ②Supply the battery power in other ways
Display code is 044	Battery Voltage abnormal warning	Check whether the battery voltage matches the system setting voltage.
Display code is 052	Temperature sensor fault	Check whether the temperature sensor plug in the machine is loose.
Display code is 053	The high internal temperature causes fault	when the temperature in standby cools to a safe temperature, resume normal charging.
Display code is 054	The battery overheated	when the battery cools to below 55°C, resume normal charging.
Display code is 055	DC Loads output fault	Please check whether the power of the DC consumer is excessive or there is a short circuit fault inside the consumer.
Display code is 056	The battery overvoltage	Measure whether the voltage across the battery is too high and disconnect the wiring of the photovoltaic array.

## 5.3 System maintenance

In order to maintain the best long-term working performance, we recommend to check the following items twice a year

- Make sure that the airflow around the controller is not blocked, and remove the dirt or debris from the air outlet of the cooling fan.
- Check whether all exposed wires are damaged due to sunlight, friction with other surrounding objects, dry rot, insect or rodent damage, etc. If necessary, the wire needs to be repaired or replaced.
- Check all the wiring terminals to see if there are signs of corrosion, insulation damage, high temperature or burning discoloration, and tighten the terminal screws.
  - Check for dirt, insect nesting and corrosion, and clean up as required.
  - If the lightning arrester has failed, replace the failed arrester in time to prevent lightning damage to the controller and even other user equipment.



**WARNING:** Beware of electric shock! When performing the above operations, make sure that all power to the controller has been disconnected, and then perform corresponding inspections or operations!

## 6. Technical parameters

### Electrical parameter

Parameter xxxxF	30415	
System rated voltage	12/24/36/48VDC or self-identification	
Controller operating voltage range	11~64V	
Lead-acid battery type	Maintenance-free (default)/colloid/liquid/custom	
Lithium battery type	Lithium Iron Phosphate/Ternary Lithium/Custom	
Rated charging current	30A	
Rated charging power	390W/12V 780W/24V 1170W/36V 1560W/48V	
Maximum open circuit voltage of photovoltaic modules	150V (under the lowest temperature condition) 138V (under 25°C condition)	
Maximum power point operating voltage range	12V system	20~150VDC
	24V system	36~150VDC
	36V system	48~150VDC
	48V system	54~150VDC
Tracking efficiency	≥99.5%	
Maximum conversion efficiency	97.5%	
Temperature compensation coefficient	-3mV/°C/2V	
Static loss	200mA/12V; 100mA/24V; 50mA/48V;	
DC load output voltage	Can be turned on in 12/24V mode	
DC load rated output current	20A	
DC load output control	Normally open normally closed mode	
Protective function	PV input reverse connection protection, battery input reverse connection protection, battery overcharge protection, battery undervoltage protection, battery over temperature protection, machine over temperature protection	
Cooling method	Wind cooling	
way of communication	RS485	
LCD backlight time	Default 60S, backlight mode can be set	
Environmental parameters		
Working environment temperature range	-20°C~+50°C	
Storage temperature range	-40°C~+70°C	
Relative humidity range	0~90%RH	
Mechanical parameters		
parameter	30415F	
Dimensions	210*150*80mm	
Recommended wiring	9AWG/6mm <sup>2</sup>	
net weight	1.45KG	





**Perum Puspa Asri Plalangan Blok R-07, Krajan 1  
Jenangan, Ponorogo, Jawa Timur, 63492**



**0822-1944-5758 / 0822-1366-5758**



**[amsanelectronics.com](https://amsanelectronics.com)**



**Tokopedia, Shopee, Tiktok  
Lazada, Bukalapak, Blibli**

